

Closed Case Cart Standard, 41" h

Simplify every step of instrument and supply management with Integro Closed Case Carts. Engineered to streamline loading, transport, and sanitization, they feature a smart case design that reduces leak and water retention after washing, along with polished stainless steel casters that stand up to corrosive conditions, frequent washdowns, and heavy loads.

This double-door cart offers options for a choice of a solid door or see-through window. Taller versions and single-door carts are also available to fit different spaces and needs. With worker-friendly features like locking casters and a safe-touch handle, these carts make every step more efficient and reliable.

Safe-touch handles cool quickly after cart wash

Optional clean/dirty indicator shows cart status, in compliance with OSHA and ANSI/AAMI standards

Stainless steel is strong, easy to clean, and corrosion-resistant

Optional preference card holder shows supply list at a glance

Stationary or roll-out shelves ease loading and secure storage

Secure door with optional high impact and scratch resistant polycarbonate window

Premium high-performance polymer bumper protects walls and doors from impact

Sturdy 6" stainless steel casters (two locking, one directional locking, and one swivel) are engineered with precision ball bearings and dual ball raceways for quiet, effortless navigation and durability.

Premium latch accommodates breakaway plastic seal to secure unopened, sterilized, or filled cart

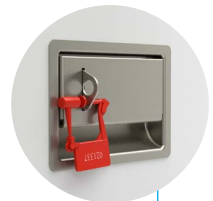

Adjustable-height shelf options available in wire or solid and adapt to storage needs



Closed Case Cart Standard, 41" h

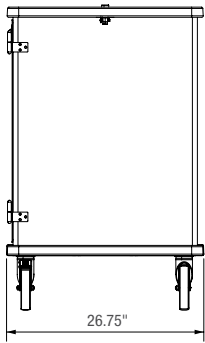
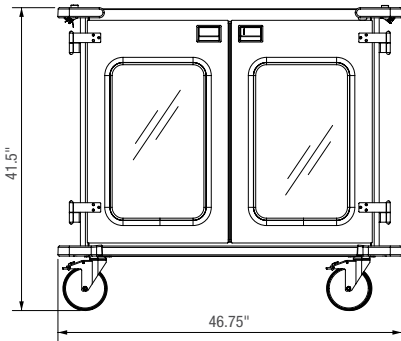

SIC4741G

1. Select Case Cart Door Type

Exterior: 46.75"w x 26.75"d x 41.5"h

Interior: 38"w x 24.25"d x 29.75"h

Weight: 285 lbs

Product Number	Description
SIC4741G	Empty cart (with window)
SIC4741S	Empty cart (solid)

2. Choose Up to Six Shelves Per Cart

Dimensions: 38.25"w x 23.25"d

Shelf increment adjustability: 2" (Recommended minimum of 1 open space between each shelf)

Roll-out Shelf Extension: 11.5"

Product Number	Description	Shelf Weight Capacity
SIC47SS	Stationary, solid shelf	150 lbs
SIC47RS	Roll-out, solid shelf	100 lbs
SIC47SW	Stationary, wire shelf	150 lbs
SIC47RW	Roll-out, wire shelf	100 lbs

3. Add Options to Customize Your Cart

Upgrade standard carts with these options (sold separately).

Product Number	Description
SICINDICATOR	Clean/dirty/neutral status indicator; stainless steel and polycarbonate
SICPREFHOLDER4x6	Preference card holders, 4"w x 6"h (2 per cart; one for each side), stainless steel
SICPREFHOLDER5x7	Preference card holders, 5"w x 7"h (2 per cart; one for each side), stainless steel
SICPREFHOLDER8x11	Preference card holders, 8.5"w x 11"h (2 per cart; one for each side), stainless steel
SICBREAKAWAY	Breakaway plastic seal, orange (pack of 100)

Materials

100% cart washer safe, from case to casters

Case	304 Stainless steel (Brushed finish)
Shelves, Wire/Solid	304 Stainless steel (Brushed finish)
Door	304 Stainless steel (Powder coat finish)
Door Window	Polycarbonate
Hinges	304 Stainless steel
Handle	High performance polymer blend
Bumper	High performance polymer blend
Casters	6" Polished stainless steel casters with polyurethane wheels